

The background is a complex, high-contrast black and white pattern. It features a central, large-scale wavy, organic shape that resembles a stylized flame or a liquid splash. This central element is surrounded by various geometric and organic patterns, including checkered grids, repeating text motifs, and circular, vortex-like designs. The overall effect is a dense, textured, and somewhat hypnotic visual field. The KTM logo is prominently displayed in the upper center, and the model name 'SCARP_EVO///' is centered below it. The year '2025' is located in the bottom right corner.

KTM
BIKE INDUSTRIES

SCARP_EVO///

**20
25**

The image features a dense, repeating pattern of stylized, elongated, leaf-like shapes in a dark orange-brown hue. The pattern is centered and covers the entire frame. In the middle of the image, the KTM logo is prominently displayed in a bold, black, italicized font. Below the logo, the words "BIKE INDUSTRIES" are written in a smaller, black, italicized, sans-serif font.

KTM
BIKE INDUSTRIES

**SCARP EVO///
TECHNOLOGY**

4

**SCARP MT
291**



24

**SCARP LT
291**



25

**SCARP
EXONIC**



15

**SCARP LT
292**



26

**SCARP
PRIME**



16

**SCARP
MASTER**



17

**SCARP MT
EXONIC
FRAMEKIT**



35

**SCARP
PROTO25
FRAMEKIT**



35

**SCARP MT
EXONIC**



18

**SCARP
PARIS
FRAMEKIT**



35

**SCARP MT
PRIME**



19

**SCARP
EXONIC
FRAMEKIT**



36

**SCARP MT
MASTER**



20

**SCARP LT
291
FRAMEKIT**



37

**SCARP MT
ELITE**



21

**SCARP MT
PRO**



22

**GEO &
FRAME SIZE**

38



OPTIMIZED FOR:

635005000000

KTM BOTTLE CAGE PRIME CBN SIDE BLK/BLK

635005001000

KTM BOTTLE CAGE PRIME CBN SIDE BLK/OR



A PIECE OF ART

- > FULL ALUMINUM
- > CNC-MACHINED
- > 49g



Mit einem Gewicht von nur 49g rundet der komplett CNC gefräste Rocker das Kunstwerk EVO III ab.

With a weight of only 49g, the fully CNC-machined rocker completes the masterpiece EVO III.



**BRAKE
INSIDE
FRAME**



HELPFUL UNIVERSAL TOOL

610009599000

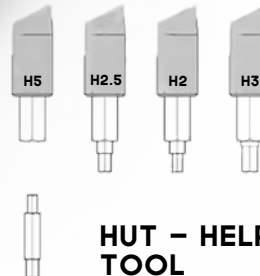
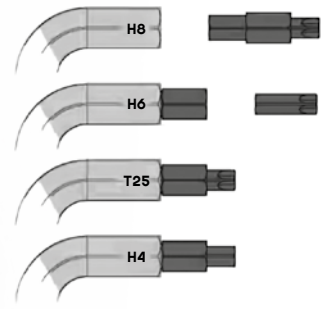

HUT – HELPFUL UNIVERSAL TOOL

Das Werkzeug immer am Bike. Aufgrund der Tatsache, dass mit einer Dropper-Post eine Montage der klassischen Satteltasche nicht immer möglich ist und Konstruktions-Lösungen mit Ausnahme im Rahmen das Gewicht und die Steifigkeit sehr Nachteilig beeinflussen, findet sich am EVO III eine kluge Eigenentwicklung in Kooperation mit Daysafer. Der Halter für das Werkzeug befindet sich, versteckt über dem Dämpfer, am Rahmen. Das Tool bietet dreizehn verschiedene Funktionen. Neben den gängigsten Torx- und Inbus-Schlüsseln, beinhaltet das Werkzeug einen Kettennieter, einen Speichenschlüssel, einen Ventilkernentferner und einen Reifenheber mit Steckplatz für ein Verschlussglied. Dies alles bei einem Gewicht von lediglich 73,3g. Des Weiteren ist eine Tool-Box sowie magnetische Bar-Ends mit Tire-Plugs erhältlich.

The tool is always on the bike. Due to the fact that mounting a traditional saddlebag is not always possible with a dropper post and construction solutions with holes in the frame are a disadvantage for weight and stiffness, the EVO III features a clever proprietary development in collaboration with Daysafer. The tool holder is located, hidden above the damper on the frame. The tool offers 13 different functions. In addition to the most common Torx and Allen keys, the tool includes a chain breaker, a spoke wrench, a valve core remover, and a tire lever with a slot for a master link. And all this at a weight of 73.3g. Furthermore, a tool box and magnetic bar ends with tire plugs are available.

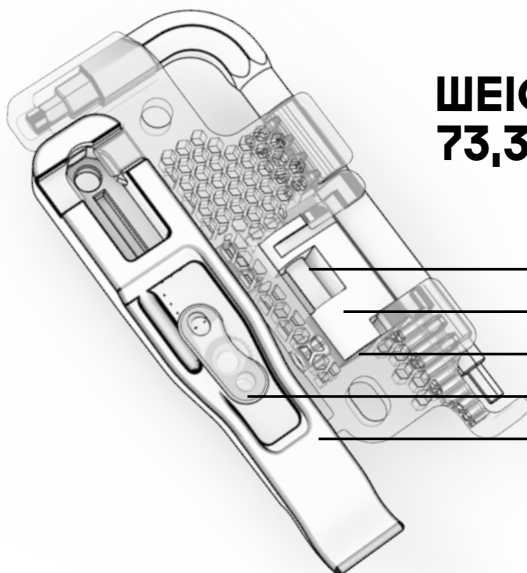

WEIGHT
73,3g

- Chain breaker
- Spoke wrench
- Valve core tool
- Chain links holder (missing link not included)
- Tire lever

BB-VOLUME



STORAGE



STIFFNESS

Mehr Volumen im Tretlagerbereich sowie die Querschnittsvergrößerung der antriebsseitigen Kettenstrebe sorgen dafür, dass jedes Watt in Vortrieb umgewandelt wird. Bei der Kettenstrebe konnte die Seitensteifigkeit im Vergleich zum Vorgängerrahmen um 48% erhöht werden – KTM bleibt benchmark.

More volume in the bottom bracket area, as well as an increase in the cross-section of the drive-side chainstay, ensures that every watt is converted into propulsion. In the chainstay, the side stiffness could even be increased by 48% compared to the previous frame

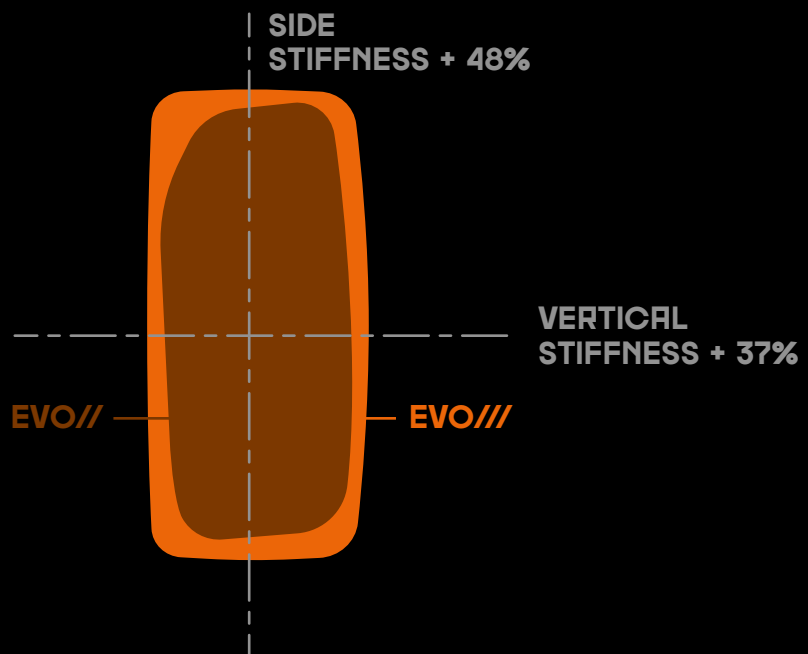

ADVANCED SEALING at main pivot



ADVANCED MAIN PIVOT SCREWS

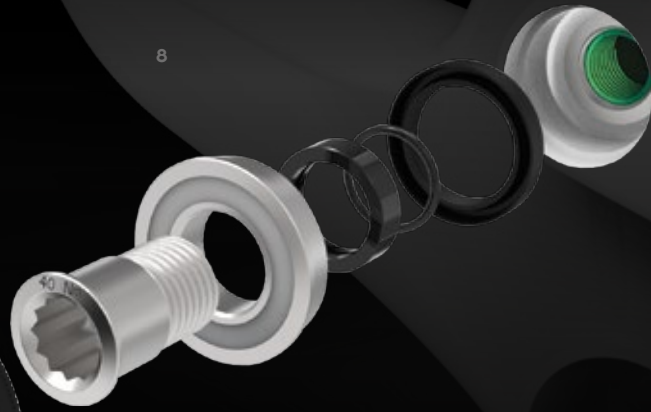

SUBMARRINE MAIN-PIVOT

Umwelteinflüsse reduzieren die Lebensdauer von Wälzlagern im harten MTB Einsatz weitaus mehr als mechanische Belastung. Das SUBMARINE MAIN PIVOT Konzept riegelt die Hauptlager der KTM Scarp hermetisch ab. Im Innern befinden sich Flanschlager, die mit 20% mehr Schmierstoff gefüllt sind und mit Heavy-Contact-Sealings ausgestattet sind. Diese Flanschlager erleichtern im Fall der Fälle zudem den Lagerwechsel erheblich. Nach außen hin wird das Lager zusätzlich noch mit einer Kappe aus Fluorkautschuk gegen Umwelteinflüsse geschützt. Zum Hauptrahmen hin gewährleisten ein Radialwellendichtring und ein Spacer mit integriertem O-Ring höchste Dichtheitswerte. Auch die Hauptlagerschraube wurde überarbeitet. Diese wird aus hochlegiertem, rostfreiem Stahl gefertigt. Das hohe Anzugsmoment von 40Nm welches mittels eines 10mm Innensechskant aufgebracht wird, sorgt für eine sichere Verbindung. Speziell geformte Aluinserts wurden hierzu in den Carbonrahmen laminiert, welche mit robusten Gewindeeinsätze aus Stahl versehen sind.

Since the service life of the ball bearings is more influenced by penetrating dirt than by extreme loads while riding, the SUBMARINE MAIN-PIVOT is utilized. Inside, there are flange bearings filled with 20% more lubricant and equipped with heavy-contact-sealings. These flange bearings also significantly facilitate the bearing replacement. Externally, the bearing is additionally protected against environmental influences with a FKM-rubber cap. Towards the main frame, a radial shaft seal and a spacer with an integrated O-ring ensure the highest sealing values. The main bearing bolt has also been redesigned. It is made of high-alloy, stainless steel. It is tightened with a 10mm Allen key (40Nm). To accommodate this tightening torque with a low frame weight, a specially shaped aluminum insert is laminated. The thread inserts made of steel are screwed into the insert provide additional protection to the thread in the frame.

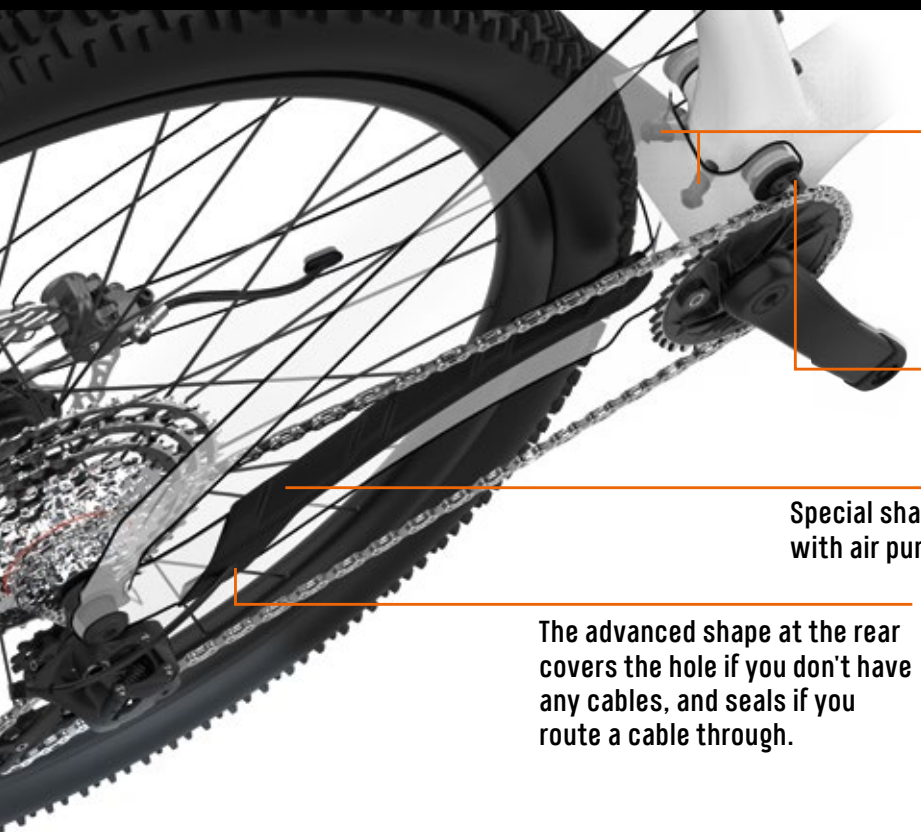

INTERNAL full covered cable routing from the top to the end

Advanced sealing
for the cables.



Small and simple
chainguide.

Special shaped CS-protector
with air pumps for a silent ride.

The advanced shape at the rear
covers the hole if you don't have
any cables, and seals if you
route a cable through.

ADVANCED SEALING FOR THE CABLES

Spezielle geformte Silikon-Röhrchen zwischen vorderem und hinterem Rahmendreieck sorgen für besten Schutz gegen eindringend Schmutz und Feuchtigkeit. Weiters verdeckt bzw. umhüllt der Kettenstrebenschutz Einlässe an der Kettenstrobe und dichtet diese ab

To prevent the penetration of dirt into the frame as effectively as possible, the internal cable routing has been further developed. Special silicone tubes between the front and rear frame triangle provide optimal protection. The chainstay protector covers or wraps around the holes on the chainstay and seals them.

CHAINGUIDE

Um sicher zu stellen, dass die Kette auch bei härtesten Belastungen und Schlägen am Kettenblatt bleibt, ist der EVO III mit einem unauffälligen, aber dafür umso wirksameren Chainguide ausgestattet.

To ensure that the chain stays on the chainring even under the toughest loads and impacts, the EVO III is equipped with a discreet yet highly effective chainguide.

ADVANCED KINEMATIC

TECHNOLOGY

MORE ANTI-SQUAT

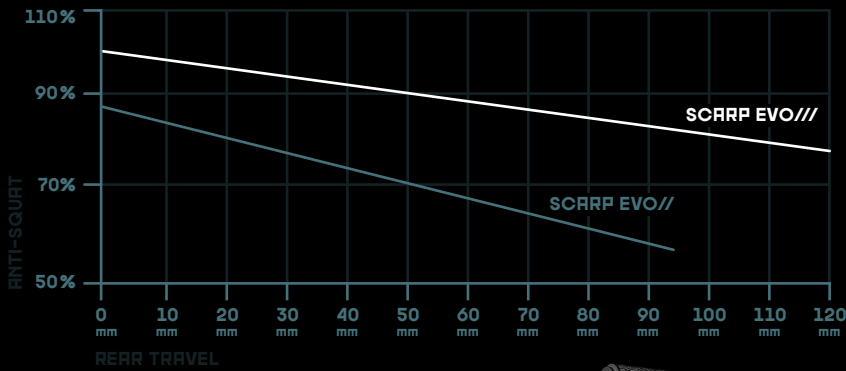

Der Wunsch unserer KTM-Weltcup-Athleten nach mehr Anti-Squat wurde im EVO III Rahmen konsequent umgesetzt. Unerwünschtes Einsacken beim harten Antritt wird noch besser eliminiert. Im Vergleich zum Vorgängerrahmen um über 20%.

Multiple times, the KTM World Cup athletes expressed the desire for more anti-squat. This prevents the undesired sinking into the suspension travel. Compared to the previous frame, this value has been increased by over 20%.



GEOMETRY UPDATE

Um den breiten hoch performanten Einsatzbereich gerecht zu werden, wurde die Geometrie noch weiter verfeinert. Dabei wurde der Lenkwinkel um 1° flacher, der Sitzwinkel um 0,5° steiler definiert. Die Oberrohrlängen sind um 10mm gewachsen, wodurch sich der Reach von 458 auf 474mm und der Stack von 605 auf 603mm (RH L/48/100mm Federweg) verändert.

To cater to all use cases, the geometry has been further optimized. The head angle is 1° flatter, and the seat angle is designed 0.5° steeper. The top tube lengths have grown by 10mm, resulting in a reach change from 458 to 474mm and a stack change from 605 to 603mm (frame size L/48/100mm travel).

MORE LOWER LEVERAGE-RATIO

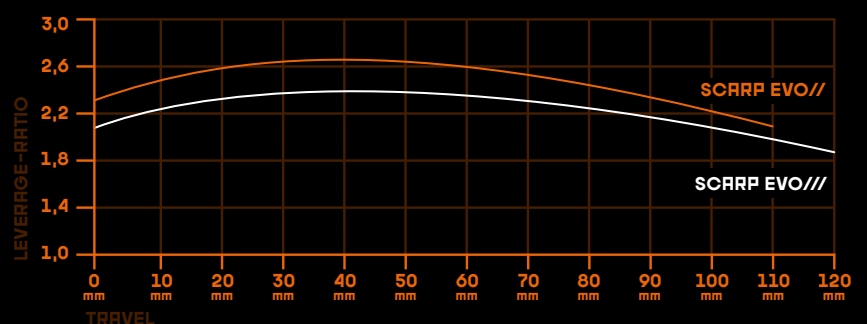

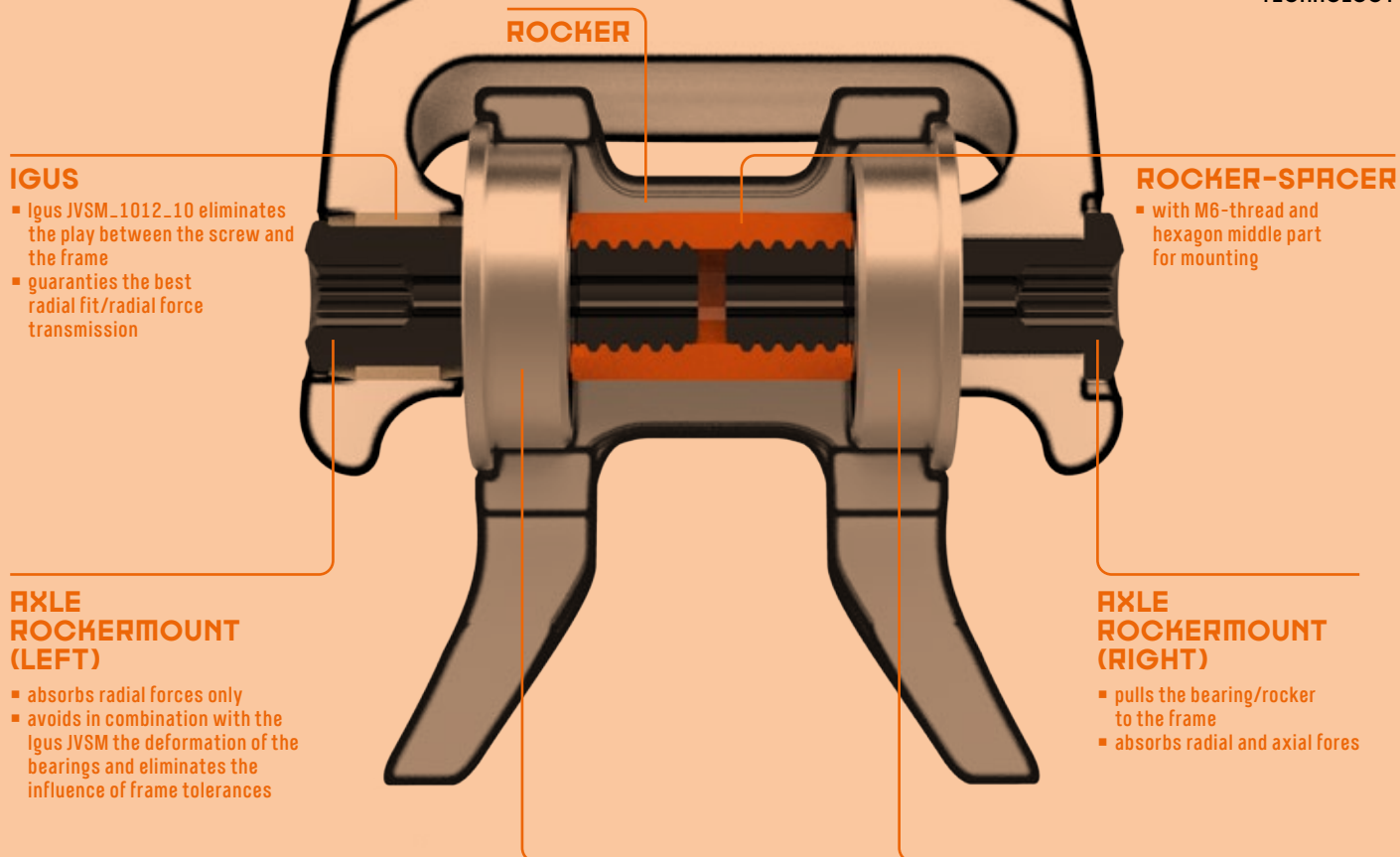

MAGIC ROCKER-ADJUSTMENT

Keine Toleranzen und kein Spaltmaß. Durch den Einsatz eines Igus-Gleitlagers weist die Montage des Rockers ein Los- und ein Festlager auf. Die verbauten Wälzlager sind somit spannungsfrei im Rocker verbaut. Auch diese Flanschlager sind mit einer extra Portion Schmierstoff sowie mit heavy-contact-sealings gerüstet.

No tolerances and no gap allowance. By using an Igus plain bearing, the assembly of the rocker features a floating bearing and a fixed bearing. This ensures that the installed ball bearings in the rocker are not axially tensioned. For the rocker as well, flange bearings with more lubricant and heavy-contact-sealings are used.

BEARING WITH FLANGE

- 90% infill
- heavy-contact sealings
- easier replacement

BEARING-CAP

- protects the bearing against water and dirt

HELICOIL®

- protects the thread-insert against damage
- enables a higher fixing torque for the screws

THREAD INSERT

- with special outer shape to withstand high torque
- alloy T6061-T6 to save weight

AXLESCREWS

WASHER WITH O-RING

protects the bearing against water

RADIAL SHAFT SEAL

protects the bearing against water and dirt

CHANGUIDE

small and simple

BEARING WITH FLANGE

- 90% infill
- heavy-contact sealings
- easier replacement

BEARING

with flange



THE NEW SCARP EVO/// RANGE

Join The Evolution

Die Rennsport-Gene des Scarp waren schon immer ein Garant für höchste Qualität und maximale Performance. Voller Stolz präsentieren wir die bereits dritte Evolutionsstufe unserer Speerspitze im Cross- und Downcountry-Bereich. Der EVO-III-Rahmen kommt bei der gesamten Range zum Einsatz und kennzeichnet den Start in eine neue Scarp-Ära. Alle Modelle sind ein Resultat aus der jahrelangen Erfahrung der KTM-Fahrrad-Ingenieure, kombiniert mit dem Feedback, direkt von den härtesten Rennstrecken der Welt. Die Ansprüche der besten Rennfahrer, an Geometrie und Fahrverhalten, konnten somit exakt in die Serie übertragen werden. Für den finalen Härte-test musste sich der Scarp-Evo-III-Rahmen beim Cape Epic in Südafrika und beim Mountainbike-Worldcup in Brasilien beweisen. Die Lobeshymnen der Athleten bestätigten die Kreation eines Meisterstückes. Besonders überzeugen die vielen technischen Feinheiten, die die Perfektion bis hin ins Detail widerspiegeln.

Den neuen Scarp-Rahmen gibt es sowohl in Carbon, als auch in Aluminium. Der Federweg variiert von 100 bis 140 mm. Vom Einsteiger-Fully bis hin zur High-End-Maschine sind dem Fahrspaß keine Grenzen gesetzt.

Als besonderes Highlight warten zudem zwei Sondereditionen als Rahmensets. Der „Scarp Proto25“-Rahmen erstrahlt im selben Erbkönig-Design, welches die Bikes der Profis während der Testphase zierte.

Die Sonderedition „Scarp Paris“ wird von den KTM-Olympioniken bei den Olympischen Spielen zum Einsatz kommen.

The racing DNA of the Scarp has always been a guarantee for highest quality and maximum performance. With great pride, we present the third evolution of our flagship in the cross- and downcountry sector. The EVO III frame is used across the entire range and marks the beginning of a new Scarp era. All models are the result of years of experience from KTM bicycle engineers, combined with feedback directly from the toughest race tracks in the world. The demands of the best racers, regarding geometry and handling, have thus been precisely transferred into production-bikes. For the final test, the Scarp Evo III frame had to prove itself at the Cape Epic in South Africa and at the Mountainbike World Cup in Brazil. The praises from the athletes confirmed the creation of a masterpiece. Particularly convincing are the many technical details reflecting perfection down to the last detail.

The new Scarp frame is available in both carbon and aluminum. The suspension travel varies from 100 to 140mm. From entry-level full-suspension bikes to high-end machines, there are no limits to your riding pleasure.

As a highlight, two special editions are waiting as frame sets. The "Scarp Proto25" frame shines in the same camouflage design that adorned the bikes of the professionals during the testing period.

The special edition "Scarp Paris" will be used by the KTM Olympians at the Olympic Games.







SCARP EXONIC

PC PREMIUM CARBON

110 mm REAR

1x12 SRAM XX SL T-TYPE

FRAME SCARP 29" Premium Carbon SLL110mm UDH / M-4920
WHEEL F KTM Exonic CC 29 CL 110/15TA 622x30TSS made by Pancho
TIRE F Schwalbe Racing Ray Evo SuperRace TLE 57-622
WHEEL R KTM Exonic CC 29 6B 148/12TA 622x30TSS made by Pancho
TIRE R Schwalbe Racing Ralph Evo SuperRace TLE 57-622
ROTOR Trickstuff Dächle UL 6B 160 / 160
CASSETTE SRAM XX SL T-Type XS-1299 / 10-52
SHOCK RockShox SID Luxe Ultimate FlightAttendant 210x50

FORK RockShox SID SL Ultimate 29" 110mm 15x110
STEM Integrated -9°
BAR FSA KFX SIC Carbon 65x780mm
GRIPS ESI Chunky silicone
SHIFTLEV. SRAM POD Rocker AXS Controller
R. DERRAIL. SRAM XX SL Eagle Transmission 12speed
BRAKE Trickstuff Piccola C22 2-Piston

CRANKSET SRAM XX SL T-Type Carbon DUB 34T Powermeter
BOTTOM BR. SRAM DUB Ceramic PressFit
CHAIN SRAM XX Eagle SL T-Type 12s
SADDLE Selle Italia SLR Boost Superflow
SEATPOST RockShox Reverb AXS wireless
HERDSET FSA ACR / Acros 1.5" angle limit
SYS.WEIGHT 121 kg (permissible total weight)
WEIGHT 10,25 kg (without pedals)



■ TRANSPARENT BLUE ON CARBON (WHITE)

- ✓ 1250305100 38cm / S
- ✓ 1250305103 43cm / M
- ✓ 1250305108 48cm / L
- ✓ 1250305113 53cm / XL



SCARP PRIME

PC PREMIUM CARBON

100 mm REAR

1x12 SRAM XX T-TYPE

FRAME	SCARP 29" Premium Carbon SLL100mm UDH / M-4920
WHEEL F	KTM Prime Carbon Trail 29 CL 110/15TA 622x30TSS made by DT Swiss
TIRE F	Schwalbe Racing Ray Evo SuperRace TLE 57-622
WHEEL R	KTM Prime Carbon Trail 29 CL 148/12TA 622x30TSS made by DT Swiss
TIRE R	Schwalbe Racing Ralph Evo SuperRace TLE 57-622
ROTOR	Shimano CL800 CL 160 / 160 Freeza

CASSETTE	SRAM GX T-Type XS-1275 / 10-52
SHOCK	RockShox SID Luxe Ultimate 3-P remote 210x47,5
FORK	RockShox SID SL Ultimate 29" 100mm 3-P remote
STEM	KTM Prime II -6"
BAR	KTM Prime II flat Carbon 720mm
GRIPS	RockShox Twistloc Grip Unit
SHIFTLEV.	SRAM POD Rocker AXS Controller
R. DERRILL.	SRAM XX SL Eagle Transmission 12speed

BRAKE	Shimano Deore XT M8100 / M8100 2-Piston
CRANKSET	SRAM XX SL T-Type Carbon DUB 34T
CHAIN	SRAM GX T-Type 12s
SADDLE	Selle San Marco Aspide Short Open Fit Narrow
SEATPOST	KTM Prime II Carbon zero 30.9/400
HEADSET	Acros ICR 1.5" angle limit
SYS.WEIGHT	120 kg (permissible total weight)
WEIGHT	10,55 kg (without pedals)



OPAL WHITE (BLACK+ORANGE)

✓	1250306100	38cm / S
✓	1250306103	43cm / M
✓	1250306108	48cm / L
✓	1250306113	53cm / XL



SCARP MASTER

PC PREMIUM CARBON

100 mm REAR

1x12 SHIMANO DEORE XT

FRAME SCARP 29" Premium Carbon SLL100mm UDH / M-4920
WHEEL F KTM Comp Trail 29 CL 110/15TA
 622x30TC made by DT Swiss
TIRE F Schwalbe Racing Ray Evo SuperRace TLE 57-622
WHEEL R KTM Comp Trail 29 CL 148/12TA
 622x30TC made by DT Swiss
TIRE R Schwalbe 57-622 TBD

ROTOR Shimano CL800 CL 160 / 160 Freeza
CASSETTE Shimano Deore XT M8100-12 / 10-51
SHOCK FOX Float SL Factory 3PTL 210x47,5
FORK FOX 32SC Float 29" Factory 100mm 15x110
STEM KTM Team II 7°
BAR KTM Team II flat 2X 720mm
GRIPS ESI Chunky silicone

SHIFTLEV. Shimano Deore XT M8100-12
R. DERRAIL. Shimano Deore XT M8100-12 SGS shadow+
BRAKE Shimano Deore XT M8100 / M8100 2-Piston
CRANKSET Shimano Deore XT M8120-12 34T
CHAIN Shimano M8100-12
SADDLE Selle San Marco Aspide Short Open Fit Narrow
SEATPOST KTM Team II 30.9/400
HEADSET Acros ICR 1.5° angle limit



CARBON (ORANGE GLOSSY + BLACK SAND)

- 🔪 1250307100 38cm / S
- 🔪 1250307103 43cm / M
- 🔪 1250307108 48cm / L
- 🔪 1250307113 53cm / XL



SCARP MT EXONIC

PC PREMIUM CARBON

120 mm REAR

1x12 SRAM XX T-TYPE

FRAME	SCARP 29" Premium Carbon SLL120mm UDH / M-4920
WHEEL F	Mavic Crossmax Ultimate 29 CL 110/15TA / 622x30TSS
TIRE F	Schwalbe Racing Ray Evo SuperRace TLE 60-622
WHEEL R	Mavic Crossmax Ultimate 29 CL 148/12TA / 622x30TC XD
TIRE R	Schwalbe Racing Ralph Evo SuperRace TLE 60-622
ROTOR	Shimano CL900 CL 160 / 160 Freeza
CASSETTE	SRAM XX SL T-Type XS-1299 / 10-52

SHOCK	FOX Float Factory 2-P remote 210x55
FORK	FOX 34SC Float 29" Factory 120mm 15x110
STEM	Integrated -9°
BAR	FSA KFX SIC Carbon 65x780mm
GRIPS	ESI Chunky silicone
SHIFTLEV.	SRAM POD Rocker AXS Controller
R. DERRAIL.	SRAM XX SL Eagle Transmission 12speed

BRAKE	Shimano XTR M9100 / M9100 2-Piston
CRANKSET	SRAM XX SL T-Type Carbon DUB 34T
CHAIN	SRAM XX Eagle SL T-Type 12s
SADDLE	Selle Italia SLR Boost flow Carbon Rails
SEATPOST	KTM Prime II Carbon zero 30.9/400
HEADSET	FSA ACR / Acros 1.5" angle limit
SYS.WEIGHT	121 kg (permissible total weight)
WEIGHT	10,15 kg (without pedals)



TRANSPARENT ORANGE ON CARBON (ORANGE)

✓	1250310100	38cm / S
✓	1250310103	43cm / M
✓	1250310108	48cm / L
✓	1250310113	53cm / XL



SCARP MT PRIME

PC PREMIUM CARBON

120 mm REAR

1x12 SRAM XX T-TYPE

FRAME	SCARP 29" Premium Carbon SLL120mm UDH / M-4920
WHEEL F	KTM Prime Carbon Trail 29 CL 110/15TA 622x30TSS made by DT Swiss
TIRE F	Schwalbe Racing Ray Evo SuperRace TLE 60-622
WHEEL R	KTM Prime Carbon Trail 29 CL 148/12TA 622x30TSS made by DT Swiss
TIRE R	Schwalbe Racing Ralph Evo SuperRace TLE 60-622

ROTOR	Shimano CL800 CL 160 / 160 Freeza
CASSETTE	SRAM GX T-Type XS-1275 / 10-52
SHOCK	FOX Float SL Factory 3PTL 210x55
FORK	FOX 34SC Float 29" Factory 120mm 15x110
STEM	KTM Prime II -6"
BAR	KTM Prime II flat Carbon 740mm
GRIPS	ESI Chunky silicone

SHIFTLEV.	SRAM POD Rocker AXS Controller
R. DERRILL.	SRAM XX SL Eagle Transmission 12speed
BRAKE	Shimano Deore XT M8100 / M8100 2-Piston
CRANKSET	SRAM XX SL T-Type Carbon DUB 34T
CHAIN	SRAM GX T-Type 12s
SADDLE	Selle San Marco Aspidi Short Open Fit Narrow
SEATPOST	KTM Prime II Carbon zero 30.9/400
HEADSET	Acros ICR 1.5" angle limit



VELVET PETROL MATT (BLACH+GOLD)

✓	1250311100	38cm / S
✓	1250311103	43cm / M
✓	1250311108	48cm / L
✓	1250311113	53cm / XL



2D
LAYOUT

SCARP MT MASTER

PC PREMIUM CARBON

120 mm REAR

1x12 SRAM XO T-TYPE

FRAME SCARP 29" Premium Carbon SLL120mm UDH / M-4920
WHEEL F Mavic Crossmax XL 29 CL 110/15TA 622x30TSS
TIRE F Maxxis Forekaster EXO/TR 3C MaxxTerra 62-622
WHEEL R Mavic Crossmax XL 29 CL 148/12TA 622x30TSS XD
TIRE R Maxxis Rekon EXO/TR MaxxTerra 62-622
ROTOR Shimano CL800 CL 160 / 160 Freeza
CASSETTE SRAM GX T-Type XS-1275 / 10-52

SHOCK FOX Float SL Perf-Elite 3PTL 210x55
FORK FOX 34SC Float 29" Performance 120mm 15x110
STEM KTM Team II 7°
BAR KTM Team II flat 2X 740mm
GRIPS ESI Chunky silicone
SHIFTLEV. SRAM POD Rocker AXS Controller
R. DERRILL. SRAM XO Eagle Transmission 12speed

BRAKE Shimano Deore XT M8100 / M8100 2-Piston
CRANKSET SRAM GX T-Type DUB wide 32T
CHAIN SRAM GX T-Type 12s
SADDLE Selle San Marco Aspide Short Open Fit Narrow
SEATPOST KTM Comp dropper internal 30.9 T:120
HEADSET Acros ICR 1.5° angle limit



TRANSPARENT BLUE ON CARBON
(ORANGE+BLUE+BLACK SAND)

1250312100 38cm / S
 1250312103 43cm / M
 1250312108 48cm / L
 1250312113 53cm / XL



SCARP MT ELITE

PC PREMIUM CARBON

120 mm REAR

1x12 SRAM S1000 T-TYPE

FRAME SCARP 29" Premium Carbon-Alloy SLL120mm UDH / M-4910
TIRE F Maxxis Forekaster EXO/TR 3C MaxxTerra 62-622
WHEEL F KTM Line - Shimano TC500B CL 32H 110-15TA
 Black Jack Ready30 32H 622x30TC
 DT Champion 2.0 black
TIRE R Maxxis Rekon EXO/TR MaxxTerra 62-622
WHEEL R KTM Line - Shimano TC500B CL 32H 148-12TA
 Black Jack Ready30 32H 622x30TC
 DT Champion 2.0 black

ROTOR Shimano RT64 CL 180 / 160
CASSETTE SRAM T-Type Eagle TBD
SHOCK FOX Float SL Perf-Elite 3PTL 210x55
FORK FOX 34 Float 29" Rhythm 120mm 15x110
STEM KTM Team II 7°
BAR KTM Team II flat 2X 740mm
GRIPS KTM Team silicone

SHIFTLEV. SRAM POD AXS Controller
R. DERRILL. SRAM Eagle Transmission 12speed TBD
BRAKE Shimano Deore M6100 / M6100 2-Piston
CRANKSET SRAM T-Type DUB wide 32T TBD
CHAIN SRAM GX T-Type 12s
SADDLE Selle San Marco Aspide Short Open Fit Narrow
SEATPOST KTM Comp dropper internal 30.9 T:120
HEADSET Acros ICR 1.5° angle limit



■ GOLDEN DUST MATT (BLACK)
 ✂ 1250313100 38cm / S
 ✂ 1250313103 43cm / M
 ✂ 1250313108 48cm / L
 ✂ 1250313113 53cm / XL



SCARP MT PRO

PC PREMIUM CARBON

120 mm REAR

1x12 SHIMANO DEORE

FRAME SCARP 29" Premium Carbon-Alloy SLL120mm UDH / M-4910
TIRE F Maxxis Rekon 62-622
WHEEL F KTM Line - Shimano TC500B CL 32H 110-15TA
 Black Jack Ready30 32H 622x30TC
 DT Champion 2.0 black
TIRE R Maxxis Rekon 62-622
WHEEL R KTM Line - Shimano TC500B CL 32H 148-12TA
 Black Jack Ready30 32H 622x30TC
 DT Champion 2.0 black

ROTOR Shimano RT30 CL 180 / 160
CASSETTE Shimano Deore M6100-12 / 10-51
SHOCK Suntour EDGE-EVO R-2CR remote 210x55
FORK RockShox Recon Silver RL 29" 120mm 2-P remote
STEM KTM Team II 7°
BAR KTM Team II flat 2X 740mm
GRIPS KTM Team silicone

SHIFTLEV. Shimano Deore M6100-12
R. DERRAIL. Shimano Deore M6100-12 SGS shadow+
BRAKE Shimano M4100 / MT410 2-Piston
CRANKSET Shimano Deore M6120-12 32T
CHAIN Shimano M6100-12
SADDLE Selle Royal SRX
SEATPOST KTM Comp dropper internal 30.9 T:120
HEADSET Acros ICR 1.5° angle limit



■ FRESH ORANGE (BLACK)

- 🔪 1250314100 38cm / S
- 🔪 1250314103 43cm / M
- 🔪 1250314108 48cm / L
- 🔪 1250314113 53cm / XL





SCARP MT 291

120 mm REAR

1x12 SHIMANO DEORE

FRAME SCARP 29" Alloy 6061 tripplebutted SLL120mm UDH / M-4900
TIRE F Schwalbe Tough Tom K-Guard 60-622
WHEEL F KTM Line - Shimano TC500B CL 32H 110-15TA
 Ryde Rival30 32H 622x30C
 DT Champion 2.0 black
TIRE R Schwalbe Tough Tom K-Guard 60-622
WHEEL R KTM Line - Shimano TC500B CL 32H 148-12TA
 Ryde Rival30 32H 622x30C
 DT Champion 2.0 black

ROTOR Shimano RT30 CL 180 / 160
CASSETTE Shimano Deore M6100-12 / 10-51
SHOCK Suntour EDGE-EVO R-2CR remote 210x55
FORK RockShox Recon Silver RL 29" 120mm 2-P remote
STEM KTM Team II 7°
BAR KTM Team II flat 2X 740mm
GRIPS KTM Comp Lock
SHIFTLEV. Shimano Deore M6100-12
R. DERRILL. Shimano Deore M6100-12 SGS shadow+

BRAKE Shimano MT201 / MT200 2-Piston
CRANKSET Shimano MT512-12 32T
CHAIN Shimano M6100-12
SADDLE KTM Line Sport
SEATPOST KTM Comp dropper internal 30.9 T:120
HEADSET Acros ICR 1.5" angle limit
SYS.WEIGHT 125 kg (permissible total weight)
WEIGHT 15,9 kg (without pedals)



EPIC GREY MATT (BLACK)

- 🔪 1250317100 38cm / S
- 🔪 1250317103 43cm / M
- 🔪 1250317108 48cm / L
- 🔪 1250317113 53cm / XL



SCARP LT 291

140 mm REAR

1x12 SRAM GX T-TYPE

FRAME SCARP 29" Alloy 6061 tripplebutted SLL140mm UDH / M-4890
WHEEL F KTM Comp Trail 29 CL 110/15TA 622x30TC made by DT Swiss
TIRE F Maxxis Rekon EX0/TR 62-622
WHEEL R KTM Comp Trail 29 CL 148/12TA 622x30TC made by DT Swiss
TIRE R Maxxis Rekon EX0/TR 62-622
ROTOR SRAM Centerline CL 200 / 180

CASSETTE SRAM GX T-Type XS-1275 / 10-52
SHOCK FOX Float PerformanceElite 2-P remote 230x65
FORK FOX 36 Float 29" Rhythm 140mm 2-P remote
STEM KTM Team II Trail35
BAR KTM Team II Trail35 rizer25 800mm
GRIPS Ergon GE10 Evo ergonomic
SHIFTLEV. SRAM POD AXS Controller
R. DERRILL. SRAM GX Eagle Transmission 12speed

BRAKE SRAM DB8 4-Piston
CRANKSET SRAM GX T-Type DUB wide 32T
CHAIN SRAM GX T-Type 12s
SADDLE Selle San Marco Aspide Short Open Fit Narrow
SEATPOST KTM Comp dropper internal 30.9 T:150
HEADSET Acros ICR 1.5" angle limit
SYS.WEIGHT 120 kg (permissible total weight)
WEIGHT 15 kg (without pedals)



■ BURNT ORANGE (BLACK)

- ✓ 1250320100 38cm / S
- ✓ 1250320103 43cm / M
- ✓ 1250320108 48cm / L
- ✓ 1250320113 53cm / XL



SCARP LT 292

140 mm REAR

1x12 SHIMANO DEORE

FRAME SCARP 29" Alloy 6061 tripplebutted SLL140mm UDH / M-4890
TIRE F Maxxis Rekon EX0/TR 62-622
WHEEL F KTM Line - Shimano TC500B CL 32H 110-15TA
 Ryde Rival30 32H 622x30C
 DT Champion 2.0 black
TIRE R Maxxis Rekon EX0/TR 62-622
WHEEL R KTM Line - Shimano TC500B CL 32H 148-12TA
 Ryde Rival30 32H 622x30C
 DT Champion 2.0 black

ROTOR Shimano RT30 CL 180 / 160
CASSETTE Shimano Deore M6100-12 / 10-51
SHOCK RockShox Deluxe Select+ 230x65
FORK RockShox Recon Gold RL 29" 140mm 15x110
STEM KTM Team II Trail35
BAR KTM Team II Trail35 rizer25 800mm
GRIPS KTM Comp Lock
SHIFTLEV. Shimano Deore M6100-12
R. DERRILL. Shimano Deore M6100-12 SGS shadow+

BRAKE Shimano M4100 / MT420 4-Piston
CRANKSET Shimano MT512-12 32T
CHAIN Shimano M6100-12
SADDLE Selle Royal SRX
SEATPOST KTM Comp dropper internal 30.9 T:150
HEADSET Acros ICR 1.5" angle limit
SYS.WEIGHT 125 kg (permissible total weight)
WEIGHT 15,6 kg (without pedals)



JUNGLE (BLACH)

- 1250321100 38cm / S
- 1250321103 43cm / M
- 1250321108 48cm / L
- 1250321113 53cm / XL



SCARP PROTO25

LIMITED
QUANTITY









SCARP
PARIS

LIMITED
QUANTITY





SCARP - PARIS

since 1964

KTM



SCARP MT EXONIC FRAMEKIT

120 mm REAR

PC PREMIUM CARBON

FRAME SCARP 29" Premium Carbon SLL120mm UDH / M-4920
FORK FOX 34K SC 29 FACT. 120 orange (blk std) KBx110
 2-PTU 910-31-502 MY24, 1.5T/44 FIT4
REM.LEVER FOX 2 POS DUAL Fork & Shock
 I-SpecEV MY24 NR: 820-07-165
SHOCK FOX FLOAT FACTORY 2-PTU E-E 210, C=22.2x8
 P=22.2x8 REV Scarp MT Exonic 25, orange std

GROMMET KTM Grommet Set
HEADSET FSA NO.55R ACR upper blk/blk glsy,1.5"/ACR/45°(KTM)
 w/o bott. bearing, w/oH-894-1
STARNUT STARNUT PRIME AERO 25.4MM w/o top cap for UP,
 w/o screw for 1 1/8" Steerer
BASE PLATE Acros base-plate 1.5" block schwarz 51.02.028R2-120
CLAMP CLT14 /34.9 UD matt finish
 D: 34.9 mm KTM PRIME Carbon, Saso

REAR AXLE KTM LIGHT TA 148 M12x1.0 rear SRAM UDH only
 blk ano. L174mm alloy 7075, w/o lever
PROTECTOR silicon protector FC-223
HANGER universal derailleur hanger UDH M12x1.0
ACCESORIES KTM Carbon Grease



TRANSPARENT ORANGE ON CARBON (ORANGE)

- 586002301100 38cm / S
- 586002301103 43cm / M
- 586002301108 48cm / L
- 586002301113 53cm / XL



WHITE ERTLHOENIG

- 586002403100 38cm / S
- 586002403103 43cm / M
- 586002403108 48cm / L
- 586002403113 53cm / XL



CRYSTAL FRESH ORANGE (WHITE)

- 586002599100 38cm / S
- 586002599103 43cm / M
- 586002599108 48cm / L
- 586002599113 53cm / XL



SCARP EXONIC FRAMEKIT

110 mm REAR

PC PREMIUM CARBON

FRAME SCARP 29" Premium Carbon SLL110mm UDH / M-4920
FORK RS SID SL ULT. FA29 DA110 blue (wht std) ST15x110
 AXS 00.4020.882.000 MY24, 1.5T/44
SHOCK RS SID LUXE ULTIM. AXS E-E 210, S:22.2x8 B:22.2x8
 FA Scarp Exonic 25, black std
GROMMET KTM Grommet Set

HEADSET FSA NO.55R ACR upper blk/blk glsy,1.5"/ACR/45"(KTM)
 w/o bott. bearing, w/oTH-894-1
STAR NUT Acros AS bearing cup ZS56 black 51.02.109
BASE PLATE Acros base-plate 1.5" block schwarz 51.02.028R2-120
CLAMP CLT14 /34.9 UD matt finish, D: 34.9 mm KTM PRIME Carbon, Saso

REAR AXLE KTM LIGHT TA 148 M12x1.0 rear SRAM UDH only
 blk ano. L174mm alloy 7075, w/o lever
PROTECTOR silicon protector FC-223
HANGER universal derailleur hanger UDH M12x1.0
ACCESORIES KTM Carbon Grease

TRANSPARENT BLUE ON CARBON (WHITE)

- 586002607100 38cm / S
- 586002607103 43cm / M
- 586002607108 48cm / L
- 586002607113 53cm / XL



SCARP LT 291 FRAMEKIT

 140 mm REAR





5 TRIPLE BUTTED ALLOY

FRAME SCARP 29" Alloy 6061 tripplebutted
FORK FOX 36A 29 RHYTHM 140 blk (stealthCM) Q15x110
 2-PTU 910-26-816 MY24, 1.5T/44 GRIP
REM.LEVER FOX 2 POS DUAL Fork & Shock
 MMX MY22 NR: 820-07-161
SHOCK FOX FLOAT P-ELITE 2-PTU E-E 230
 C=22.2x8 P=22.2x8 REV Scarp LT 291 25, stealth CM

GROMMET KTM Grommet Set
HEADSET KTM Headset 1 1/8"- 1 1/8/1.5"
STAR NUT STAR NUT-SYSTEM TK-SCF-3 black 1 1/8"
 50% matt/bik Logo TC KTM TEAM, black alloy-screw
BASE PLATE KTM SPACER-KONISCH 5MM black matt
 35>32mm Al6061, ATR-28.6-5-KTM

CLAMP FJ21-1 /34.9 anodized-black,
 D: 34.9mm Al6066
REAR AXLE KTM COMP TA 148 M12x1.0 rear SRAM UDH only
 blk ano, L173mm alloy 6061, w/lever
HANGER universal derailleur hanger UDH M12x1.0
ACCESORIES KTM Carbon Grease

BURNT ORANGE (BLACK)

 586002210100 38cm / S
 586002210103 43cm / M
 586002210108 48cm / L
 586002210113 53cm / XL

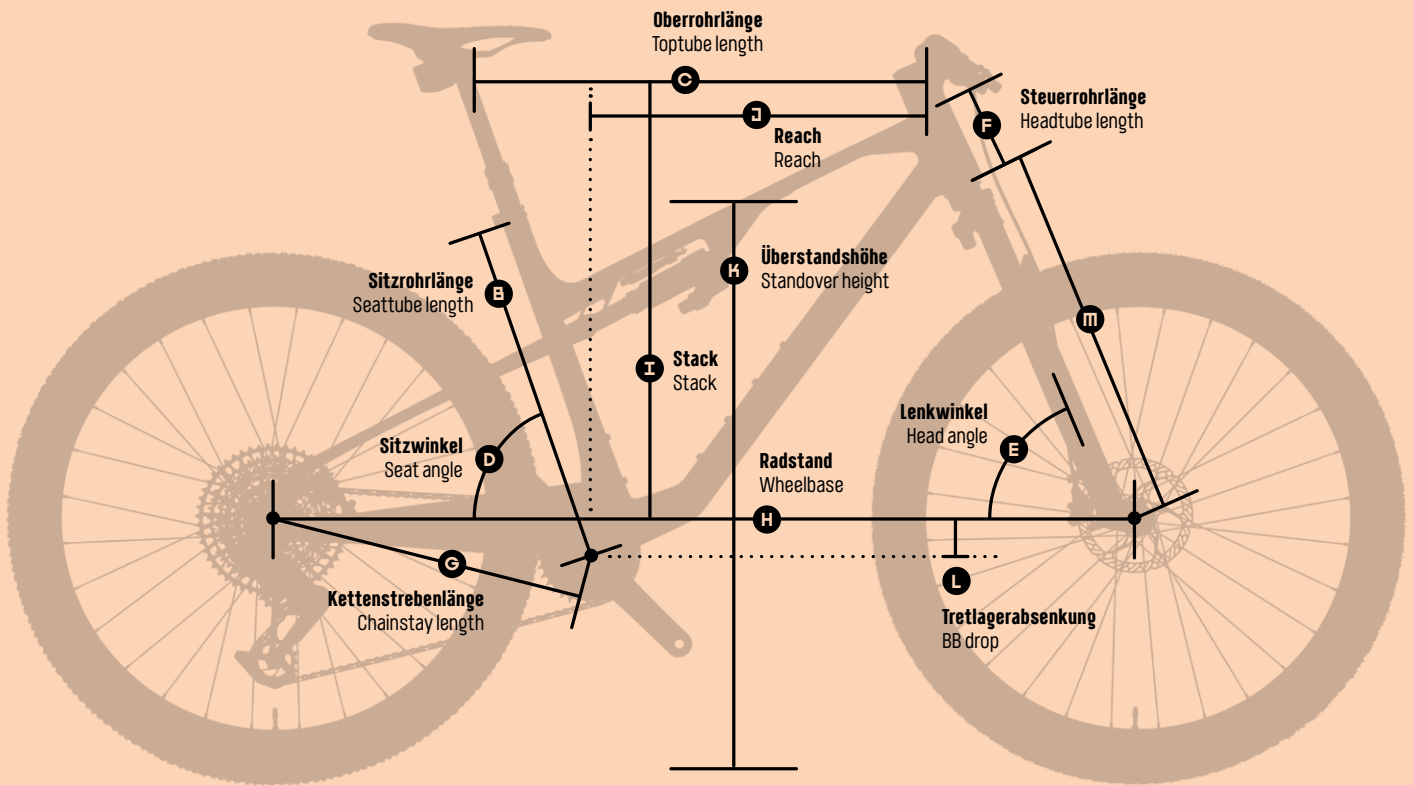

GEO

	R / SIZE	B	C	D	E	F	G	H	I	J	K	L	M
SCARP 100mm	38cm / 15" / S	380	590	75.5° (70°)	67.5°	95	435	1143	584	439	422.7	45	506
	43cm / 17" / M	430	610	75.5° (70.5°)	67.5°	105	435	1164	594	457	449.4	45	506
	48cm / 19" / L	480	630	75.5° (71.1°)	67.5°	115	435	1185	603	474	454.1	45	506
	53cm / 21" / XL	530	650	75.5° (71.5°)	67.5°	125	435	1207	612	492	458.7	45	506
SCARP EXONIC 110mm	38cm / 15" / S	380	591	75° (69.5°)	67°	95	435	1146	588	434	427	42	516
	43cm / 17" / M	430	611	75° (70°)	67°	105	435	1168	597	452	431	42	516
	48cm / 19" / L	480	631	75° (70.7°)	67°	115	435	1189	607	469	435.7	42	516
	53cm / 21" / XL	530	651	75° (71°)	67°	125	435	1211	618	487	441	42	516
SCARP MT 120mm	38cm / 15" / S	380	593	74.4 (68.9°)	66.4°	95	435	1152	530	428	433	37	530
	43cm / 17" / M	430	613	74.4 (69.4°)	66.4°	105	435	1173	530	445	438	37	530
	48cm / 19" / L	480	633	74.4 (70°)	66.4°	115	435	1195	530	463	443	37	530
	53cm / 21" / XL	530	653	74.4 (70.5°)	66.4°	125	435	1216	530	480	448	37	530
SCARP LT 140mm	38cm / 15" / S	380	590	75.5°	65.5°	100	435	1189	611	443	443	33	554
	43cm / 17" / M	400	610	75.5°	65.5°	110	435	1211	620	461	449	33	554
	48cm / 19" / L	450	630	75.5°	65.5°	120	435	1233	629	479	454	33	554
	53cm / 21" / XL	480	650	75.5°	65.5°	130	435	1255	638	497	459	33	554

FRAME SIZE

RAHMENGRÖSSE

BODY HEIGHT Körpergröße	140cm — 154cm	155cm — 164cm	165cm — 169cm	170cm — 174cm	175cm — 179cm	180cm — 184cm	185cm — 189cm	190cm — 194cm	194cm — 200cm
MTB FULLY	S 38 cm	M 43 cm	L 48 cm	XL 53 cm					

Note: This chart provides you only a rough indication!

Achtung: Diese Tabelle dient nur zur ungefähren Bestimmung!

The image features a dense, repeating pattern of stylized, overlapping leaf or feather shapes in a dark brown, almost black, color. The pattern is highly detailed and covers the entire background. In the center, the KTM logo is prominently displayed. The logo consists of the letters 'KTM' in a bold, italicized, sans-serif font, with a horizontal bar above the 'M'. Below the 'KTM' logo, the words 'BIKE INDUSTRIES' are written in a smaller, italicized, sans-serif font.

KTM
BIKE INDUSTRIES

KTM
BIKE INDUSTRIES

KTM-BIKES.AT

**KTM FAHRRAD
GMBH**

Harlochnerstraße 13
5230 Mattighofen
Austria

**KTM FAHRRAD
DEUTSCHLAND GMBH**

Adolf-Kolping-Straße 34
D-84359 Simbach am Inn
Germany

Technische Änderungen ohne weitere Information vorbehalten. Für Irrtümer und Druckfehler keine Haftung. Stand: April 2024
Specifications are subject to change without notice. For errors, technical mistakes and misprints no liability is assumed. Stand: April 2024